

## A SYSTEM FOR NONINVASIVE PORTABLE QUANTITATIVE SEISMOCARDIOGRAPHY SIGNAL EVALUATION

Z. Trefny\*, M. Stork\*\*

\* Cardiological laboratory in Prague, Argentinska 17, 17000 Praha, CZ

\*\* University of West Bohemia, Plzen, Czech Republic

z.m.trefny@mbox.vol.cz, stork@kae.zcu.cz

**Abstract:** Quantitative seismocardiography (Q-SCG) opens a new field of cardiovascular dynamics examination. Using this absolutely non-invasive method, a new field of monitoring heart rate variability was opened up. Systolic forces as well as heart rate variability in relation to changes in external stimuli are registered. Q-SCG probably offers a more complex view of both inotropic and chronotropic heart functions. It will be suitable for: examining operators exposed to stress; for assessing the effect of work, fatigue and mental stress; for monitoring persons as part of disease prevention; for determining a person's ability to carry out their duties both on the ground and in the air. An electronic system for acquisition of data for noninvasive Q-SCG and signal processing is also presented. The measuring system is based on 16-bit sigma-delta analog/digital converter, microcontroller and personal computer. A special digital smoothing polynomial filter is used for signal processing. The example of real measured and evaluated signal is also shown.

### Introduction

#### *Balistocardiography (BCG)*

In balistocardiography body vibrations caused by the heart activity are registered. Balistocardiography is a non-invasive method enabling the examination of the cardiovascular dynamics. This field has a longer history than is commonly known. William Harvey (1578-1657) who discovered blood circulation called his work, published in 1628, „Exercitatio anatomica de motu cordis et sanguinis in animalibus.“ As the title suggests, this work covers two main topics:

- a) Movement of the heart
- b) Movement of the blood

Harvey also states that movement is one of the basic functions that sustain circulation. This process requires impulse and force (*impetus et violentia*), which are produced by the heart (*impulsor*). The heart itself may „produce force and impulse“, while blood is propelled and forced to “leave its source and home” towards the peripheral parts of the body.

In 1936, Starr took part in a conference held by the American Society of Physiology which dealt with methods of determining cardiac output. For this

purpose, he used a bed with tight springs, whereby by the movement against these springs increased the instrument's natural frequency to values higher than the heart rate. Thus began the era of high-frequency balistocardiography, which lasted approximately 15 years. Other types of instruments were developed later on which measured the displacement, velocity or acceleration of a body lying on a bed. Later studies showed that there are difficulties when comparing records registered on different apparatuses. This is mainly caused by two factors:

- a) The instrument's natural frequency
- b) The instrument's damping

The instrument's natural frequency lies within the range of the frequencies caused by the cardiac activity that we wish to observe. This leads to interference and the subsequent recording is a summation of the oscillations of the instrument and those of the heart. The other factor that significantly affects the shape of the registered curve is the damping installed in these instruments (which are basically oscillatory systems) in order to prevent the periodic oscillations of the instruments themselves. Records of heart activity are therefore deformed.

#### *Quantitative balistocardiography (Q-BCG)*

Following the critical evaluation of all these facts, we began in 1952 our own experiments related to the construction of an apparatus which would lack the aforementioned shortcomings. Thus, over the years, we constructed an apparatus whose advantages lie not only in the simplicity of its design, but also in its important functional qualities.

The properties of the pick-up device and bearing structure, the subject's sitting position in close contact with the seat and an amplifier with a sufficiently long time constant reduce the possibility of shape, phase and time deformation of the records. All this enabled us to conduct a physical and mathematical analysis of the balistocardiographic system and to calibrate our instrument. Based on these processes, we designated our apparatus a quantitative balistocardiograph. This was chiefly to distinguish it from previous instruments that registered displacement, velocity and acceleration and were designed to determine cardiac output on one hand, and also because our instrument was calibrated so that force expressed in Newtons registers an amplitude

measurable in mm, whereby the relationship between the size of the active force and the registered amplitude is linear, on the other hand. Our quantitative balistocardiographic method enabled us to introduce two characteristic quantities: systolic force (F) and minute cardiac force (MF), thus using quantitative balistocardiography in an exact manner when studying cardiovascular dynamics at rest and during stress.

Current applications of Q-BCG: In papers published to date we drew on the fact that the relationship between the force acting on the pick-up device and the amplitude of the balistocardiographic curve is linear. This enabled us to study the evolution of systolic force in relation to age and ageing, the influence of hypoxia and hyperoxia. We were also able to follow the changes in Q-BCG indices at rest and under workload in various groups of volunteers, and to determine the linear relationship between the skeletal muscle force and systolic force, and determine changes in Q-BCG indices in various pathological states. We also compared our parameters, determined by Q-BCG, with parameters determined using other non-invasive methods.

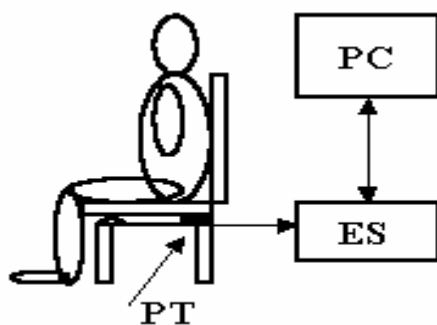

Figure 1: Principle of the noninvasive quantitative seismocardiography measuring:  
PT - piezoelectric transducer, ES - electronic system, PC - personal computer

#### Quantitative seismocardiography (Q-SCG)

During a visit to the Flight Psychophysiology Laboratory at Wright-Patterson Airforce Base, a new application field for Q-BCG emerged. This made use of the fact that our method enables the recording of force applied without phase or time deformation. Thus, heart rate may be monitored and analyzed using the method of heart rate variability. The method of Q-BCG was designated by the laboratory employees as absolutely non-invasive, as the persons examined did not have any electrodes attached to the body surface and was not connected by cables to the registering instrument. This new field of monitoring heart activity, whereby we determine both amplitude-force and time-frequency relationships, is termed Q-SCG. Thus, one may determine the force-response of the cardiovascular system to changes in external stimuli, as well as the autonomous nervous system regulation of the circulation and the activity of the sympathetic and parasympathetic systems.

The basic part of the Q-SCG is a rigid piezoelectric force transducer resting on steel chair. The examined person sits on the seat placed on the transducer and force caused by the cardiovascular activity is a measured (Figure 1). The natural frequency of the chair is higher than 1 kHz so that there is no interference with the vibrations caused by the heart activity. Neither damping nor isolation from building vibrations are necessary. These properties enabled to calibrate seismocardiographic system and determine the absolute value of force acting upon the pick-up-device, [1], [2], [3].

The system described in the present study enable better signal evaluation based on high resolution analog/digital converter (ADC), digital filtration and digital correction of nonlinearities and noise suppression by means of personal computer (PC). The heart rate (HR), systolic force (F), minute cardiac force (MF) and breathing frequency (BF) is non-invasively measured.

#### Materials and methods

The electronic system used for data acquisition consists of a piezoelectric force transducer (PT), analog front end for low frequency measurement applications (containing ADC), microcontroller and PC. The block diagram of the whole system is shown in Figure 2. It is important to note, that amplitude of measured signal from PT is under 1 mV (depend on subject heart activity) and desired frequency spectrum is lower than 30 Hz.

The measured signal is corrupted by strong noise, baseline wander, etc. therefore the digital signal processing (DSP) is used for signal denoising.

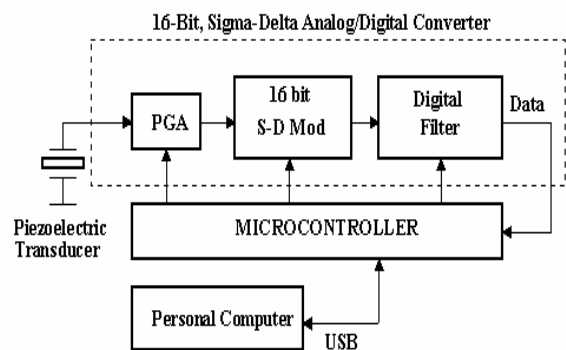

Figure 2: The simplified block diagram of the electronic system for seismocardiography measuring. The main parts of the system are:

Piezoelectric force transducer, PGA - programmable gain amplifier, S-D Mod - 16-bit sigma-delta modulator, digital filter, microcontroller and personal computer connected to system by means of USB (Universal serial bus).

The analog front end, based on AD7707 is tree-channel device which can accept either 2 low level input signals (+10 mV to +1.225 V or ± 10 mV to ±1.225 V, depends on PGA setting) directly from transducer or

one high level signal (+10 V or ± 10 V) and produce serial digital output [4]. It employs a sigma-delta conversion technique to realize up to 16 bits of no missing codes performance.

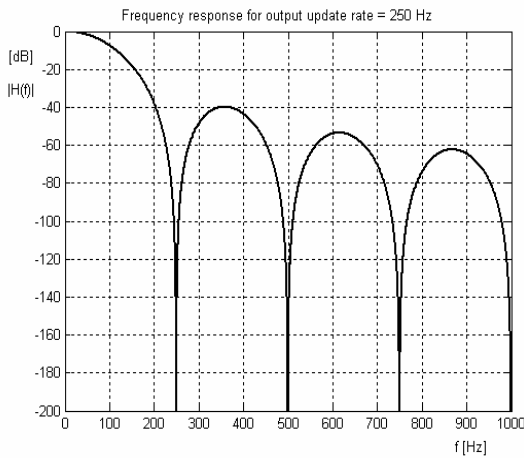

Figure 3: Frequency response of a  $(\sin x/x)^3$  AD7707 digital filter for output update rate of 250 Hz.

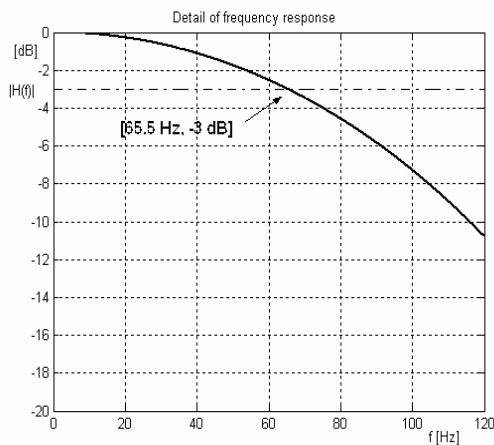

Figure 4: Detail of frequency response of a  $(\sin x/x)^3$  AD7707 digital filter for output update rate of 250 Hz.

The sigma-delta modulator output is processed by an on-chip digital filter. The first notch of this digital filter can be programmed via an on-chip control register allowing adjustment of the filter cutoff (1.06 Hz to 131 Hz) and output update rate (4.054 Hz to 500 Hz). The -3 dB frequency  $f_{-3dB}$  is determined by the programmed first notch frequency according to the relationship (1):

$$f_{-3dB} = 0.262 * f_{FN} = 0.262 * f_s \quad [\text{Hz}] \quad (1)$$

where  $f_{FN}$  is filter first notch frequency and  $f_s$  is output update rate (sampling rate). The AD7707's digital filter is a low-pass filter with a  $(\sin x/x)^3$  response (also called  $\text{sinc}^3$ ). The transfer function for this filter is described in z-domain by:

$$H(z) = \left| \frac{1}{N} \cdot \frac{1-z^{-N}}{1-z^{-1}} \right|^3 \quad (2)$$

and in the frequency domain by:

$$H(f) = \left| \frac{1}{N} \cdot \frac{\sin(\pi N f / f_s)}{\sin(\pi f / f_s)} \right|^3 \quad [\text{Hz}] \quad (3)$$

where N is the ratio of the modulator rate to the output rate (modulator rate is 19.2 kHz for Xtal=2.4576 MHz).

The frequency responses of the digital filter are shown in Figure 3 and Figure 4. Phase response is given by (4):

$$\text{Phase}(f) = -3 \pi (N-2) f f_s \quad [\text{Rad}] \quad (4)$$

The data from A/D converter are next filtered also by Savitzky-Golay Smoothing filter (SG).

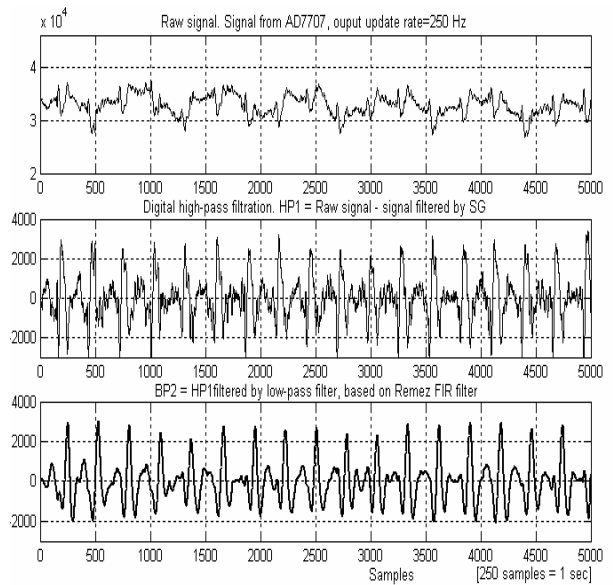

Figure 5. Record of the Q-SCG in normal man, age 45 years, 78 kg, after lowpass and highpass filtration (left). Raw signal is filtered by SG filter and Remez finite impulse response (FIR) filter; 250 samples = 1 sec.

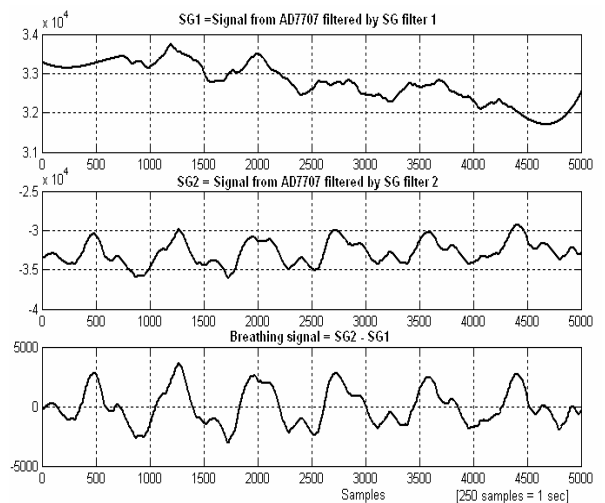

Figure 6: Breathing frequency derived from raw signal by means of two SG filters.

Savitzki and Golay defined a family of filters which are suitable for smoothing and/or differentiating sampled data (commonly called Savitzki-Golay, DISPO - Digital Smoothing Polynomial, or least-square smoothing) [5], [6], [7], [8]. The data are assumed to be taken at equal intervals. The smoothing strategy is derived from the least squares fitting of a lower order polynomial to a number of consecutive points. For example, a cubic curve which is fit to 5 or more points in a least squares sense can be viewed as a smoothing function.

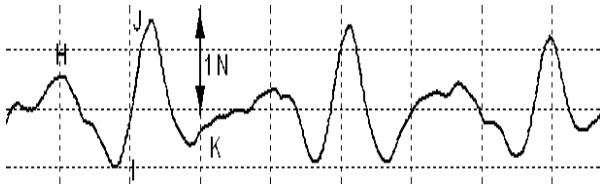

Figure 7: The systolic force ( $F$ ) determination from Q-SCG measured signal (from points: H, I, J K).

An example of Q-SCG measurement is illustrated in Figure 5. The output update rate was 250 Hz,  $f_{-3dB}$  was 62.5 Hz. The three SG filters with different window length were used for Q-SCG and breathing signal processing. Data on Y axis are decimal values of A/D converter. After calibration (Y axis in Newton), the systolic force  $F$  and minute cardiac force  $MF$  can be computed according (5) and (6):

$$F = (F_{HI} + F_{IJ} + F_{JK})/3 \quad [\text{N}] \quad (5)$$

$$MF = F * HR \quad [\text{N. beats/min}] \quad (6)$$

where  $HR$  is heart rate and  $F_{HI}$ ,  $F_{IJ}$ ,  $F_{JK}$  can be found according Figure 7. The systolic force represents the force response caused by the heart activity and is expressed in units of force [Newton]. For the total intensity of the heart activity is introduced the minute cardiac force which equals the systolic force multiplied by the  $HR$ .

## Discussion

The anatomy and function of single organs of human organism are in correlation. This is true for muscle mass, the body weight and the muscle force too. The reason of this fact is that higher body weight needs for the defined movement greater force, which cannot be realised but by the development of the skeletal musculature. Consequently greater musculature needs more energy which is transported and distributed by the cardiovascular system. In addition, the increased performance of the cardiovascular must be adjusted by the heart muscle. From these relationships it can be concluded that there must be not only the correlation between the skeletal muscle force and the heart mass but also between the skeletal muscle force and the systolic cardiac force as it was observed in the present study.

According to our opinion these results may be extrapolated generally for healthy men without pathological changes in cardiovascular system.

## Conclusion

The principles of Q-SCG, measuring system, and signal processing were shown. The application of Savitzki-Golay filter was also described.

## Acknowledgment

Zdenek Trefny preparing this paper has been supported by: Grant Eureka E! 2249.

Milan Stork's participation has been supported by: Department of Applied Electronic and Telecommunication, University of West Bohemia.

## References

- [1] TREFNY Z., TREFNY M., DAVID E., MACHOVA J., SVACINKA J. (1996): 'Some physical aspects in cardiovascular dynamics', *J. Cardiovaasc., Diag. and Procedures*, **13**, No: 2, pp. 141-45.
- [2] TREFNY Z., SVACINKA J., TREFNY M., TROJAN S., SLAVICEK J., KITTNAR O. (1998): 'Relation between cardiac force and maximal skeletal muscle force', *Journal of Physiology*, Cambridge University Press.
- [3] TREFNY Z., SVACINKA J., TREFNY M., DAVID E., DAVID V., TROJAN S., SLAVICEK J., KITTNAR O. (1998): 'Noninvasive method - quantitative balistocardiography (Q-BCG) and its value', XIII. Congress of the Cardiovascular System Dynamics Society, Gent., Belgium.
- [4] AD7707, 3-Channel 16-bit, Sigma-Delta ADC, Analog Devices, Internet site address <http://www.analog.com>
- [5] SAVITZKI AND GOLAY (1964): 'Smoothing and Differentiation of Data by Simplified Least Squares Procedures', *Analytical Chemistry*, vol. **36**, no. 8, pp. 1627-38.
- [6] MADDEN H. (1978): 'Comments on Smoothing and Differentiation of Data by Simplified Least Square Procedure', *Analytical Chemistry*, vol. **50**, no. 9, pp. 1383-86.
- [7] BROMBA U., ZIEGLER H. (1981): 'Application Hints for Savitzki-Golay Digital Smoothing Filters', *Analytical Chemistry*, vol. **53**, no. 11, pp. 1583-86.
- [8] KING R., RUFFIN C., LAMASTUS F., SHAW D. (1999): 'The Analysis of Hyperspectral Data Using Savitzki-Golay Filtering - Practical Issues (Part 2)', IEEE IGARSS '99 proceedings.